



CANISTER GUARD® & IBOP VALVES

VALVES

CANISTER GUARD® VALVES

M&M International CANISTER GUARD® valves are designed and manufactured in-house at our headquarters in Broussard, Louisiana, and are offered in:

- Standard and H2S service
- 10,000 and 15,000 psi working pressures
**Higher pressures available upon request*
- Class 2 (bidirectional sealing and designed for downhole applications)



CANISTER GUARD®

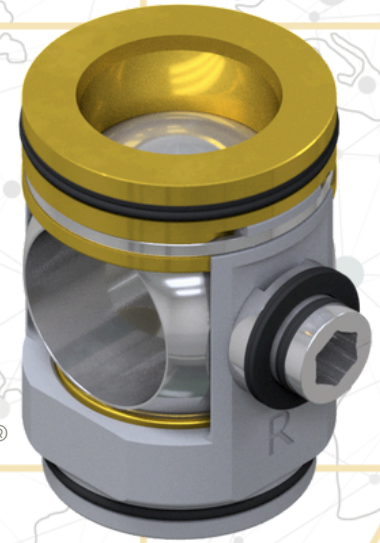

ONE-PIECE KELLY VALVES WITH CANISTER GUARD®

Our One-Piece CANISTER GUARD® Kelly Valves are extremely versatile and can be utilized in multiple drill string applications. Depending on the customer's desired configuration, they can be used as upper/lower kelly cocks, stabbing valves, or as mud saver valves.

TWO-PIECE KELLY VALVES WITH CANISTER GUARD®

Our Two-Piece CANISTER GUARD® Kelly Valves include the features of our one-piece valves while also allowing for larger inside diameters than are possible in one-piece configurations. Along with allowing a more expanded range of capabilities through the larger inside diameter, the two-piece design can also add ample length for connection recuts. Two-piece kelly valves can be manufactured to all of the same standards as one-piece kelly valves and include all of the same patented technologies.

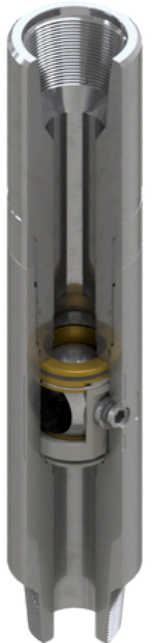

GET IN
TOUCH

(337) 364-4145
SALES@MM-INTL.COM
WWW.MM-INTL.COM



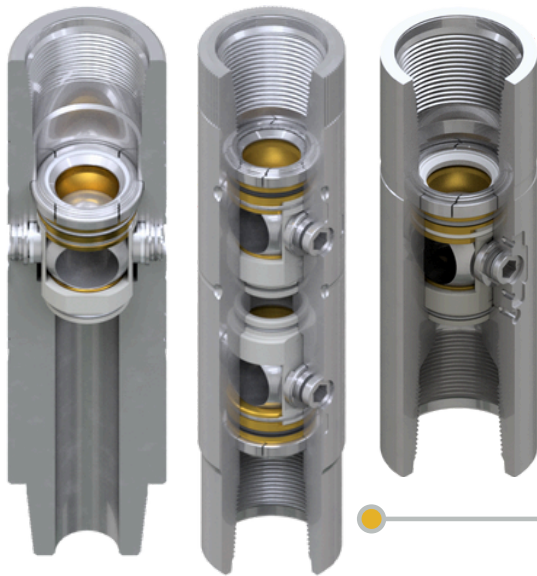

TOP DRIVE SAFETY VALVES WITH CANISTER GUARD®

We manufacture valves and saver subs that are specially designed to operate in conjunction with various makes and models of top drive. Our upper and lower top drive valves incorporate all the CANISTER GUARD® technologies that make M&M International valves superior to other designs.



TOP DRIVE SAFETY VALVES WITH BOTTOM LOAD™ SYSTEM & CANISTER GUARD®

M&M's Top Drive Safety Valve Bottom Load™ lower valves have an extended pin nose profile that matches the mating ID profile of M&M's Top Drive Safety Valve Bottom Load™ upper valves. These valve systems have the all-important, rig downtime saving, Bottom Load™ feature. When the time comes for scheduled routine maintenance, the lower valve only needs to be removed to allow quick and easy access to the upper valve's internal components. Along with its innovative design features and our CANISTER GUARD® technology, the Top Drive Safety Valve Bottom Load™ system allows for the quickest possible inspection and/or redress procedure. Since its inception over 20 years ago, M&M's Top Drive Safety Valve Bottom Load™ system has saved countless hours of rig downtime.

TWO-PIECE SAFETY VALVES WITH CANISTER GUARD®

Our Two-Piece Safety Valves also incorporate our CANISTER GUARD® technology and can be designed and manufactured with any tubing, casing, or drill pipe connection(s). When workover and/or completion activities call for a full-bore opening safety valve, this valve will ensure safety and peace of mind during your operations.

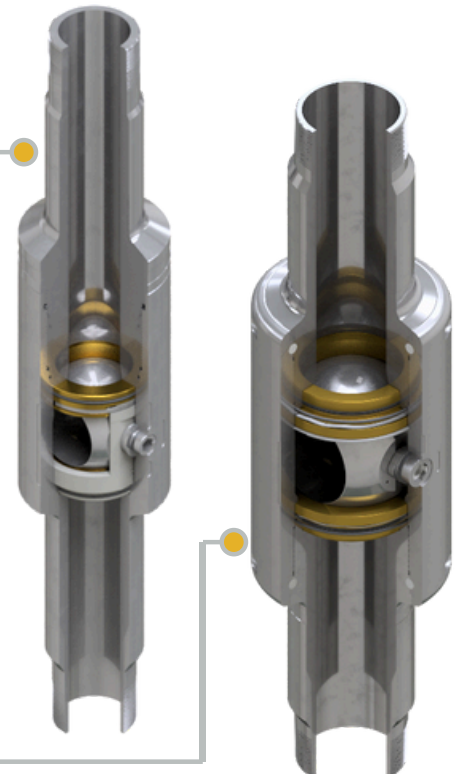

THREE-PIECE SAFETY VALVES WITH CANISTER GUARD®

Our innovative Three-Piece Safety Valve ("3PV") with CANISTER GUARD® design is a proven winner when it comes to how versatile a larger more expensive valve can be. One, or both, of the end pieces of the 3PV can be removed and easily switched out in the event of connection damage or if a connection change is required. Spare end pieces can be kept on the rig floor for easy replacement should the need arise. Further, end pieces with different connections can be kept on the shelf by the customer allowing the same 3PV to be used on another job requiring different connections. *Cage not required in largest size.

INSIDE BLOWOUT PREVENTER (“IBOP”)/DART VALVES

M&M International IBOP valves are designed and manufactured in-house at our headquarters in Broussard, Louisiana, and are offered in:

- Standard and H2S service
 - 10,000 and 15,000 psi working pressures
- *Higher pressures available upon request



ONE-PIECE IBOP

M&M's One-Piece IBOP offers all the same functionality of a traditional two-piece design, but with the addition of several key benefits. A one-piece design allows the IBOP to be shorter in length while also creating the possibility for smaller outside diameters. The one-piece design also eliminates the service break, which removes the need to torque a connection after assembly and allows for quicker disassembly, as there is no connection to break out. One-piece IBOPs also require less manufacturing time than two-piece, allowing for a faster lead time offering to the customer. Our IBOPs can be designed and manufactured to meet any applicable industry standard.

TWO-PIECE IBOP

M&M's Two-Piece IBOP is our improved version of the long-time standard for dart valves in the industry. We make it our own by manufacturing our IBOPs out of superior materials and with our best in class engineering and attention to detail. That is why M&M IBOPs are well known in the industry as time tested and reliable performers. Our IBOPs can be designed and manufactured to meet any applicable industry standard.

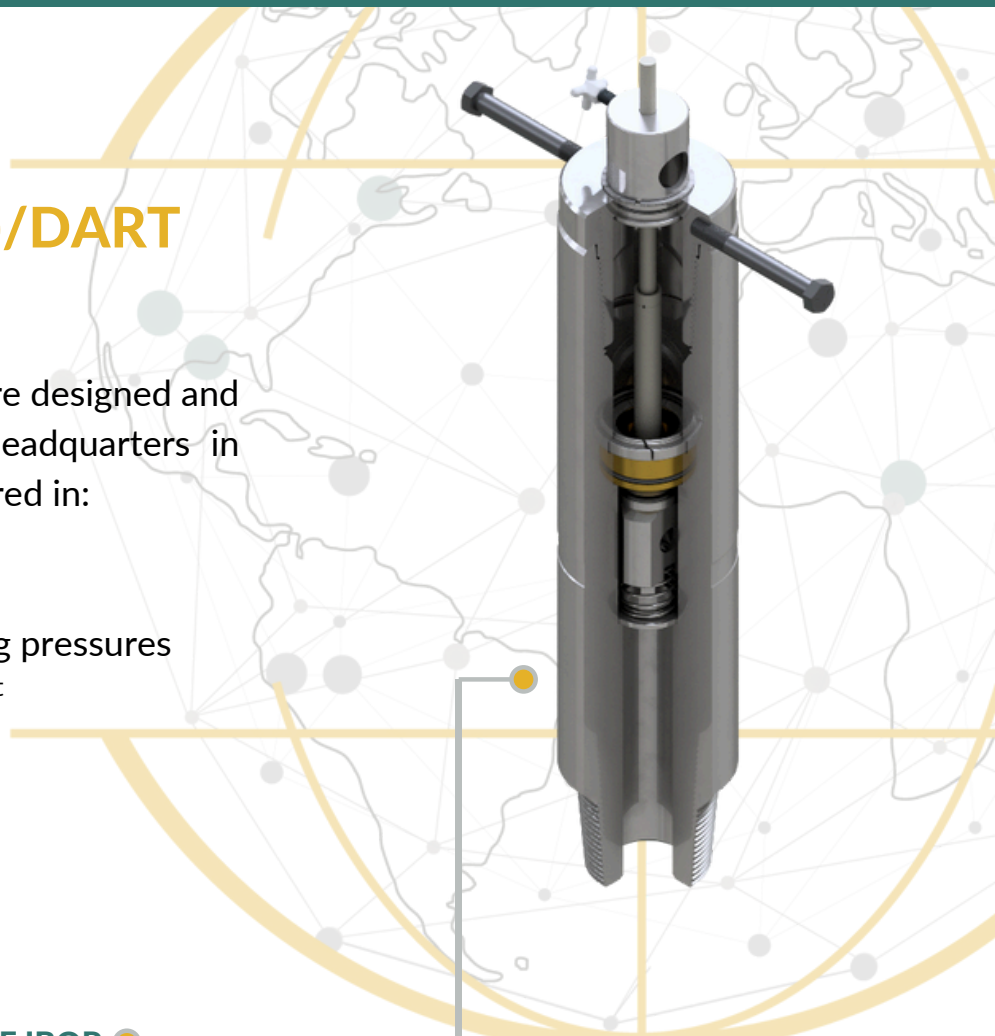



SMART SOLUTIONS. CHOICE.

CONTACT US TODAY TO LEARN MORE ABOUT WHY

M&M International

IS THE SMART CHOICE WHEN IT COMES TO
WELL CONTROL SAFETY VALVES.

GET IN
TOUCH

(337) 364-4145
SALES@MM-INTL.COM
WWW.MM-INTL.COM

